

APEX Technologies Catalog

AInnoTech
(주)에이이노텍
FiberAll
www.FIBERALL.co.kr
광통신 전문 소평몰! 파이버올!

www.AINNOTECH.com
Email: korea@ainnotech.com
TEL:02,409,3222 FAX:02,409,3229
서울시 송파구 가락동 10-9 현성 B/D 2F

OPTICAL TEST & MEASUREMENT



APEX
TECHNOLOGIES

Experts in next generation test equipment



Experts in next generation test equipment

Created on 1998, APEX Technologies is located in the south of Paris in France. For over 15 years, APEX Technologies has focused on developing and manufacturing innovative ultra high performance test equipment intended for fiber optic telecommunications research. Since introducing the world's first commercially available ultra high resolution optical spectrum analyzer, APEX Technologies has also been dedicated to the continued development of the optical measurement area. Our experience means we know that innovations never cease, and we are driven by the "knowledge is power" policy in order to stay at the top of the advanced technology.

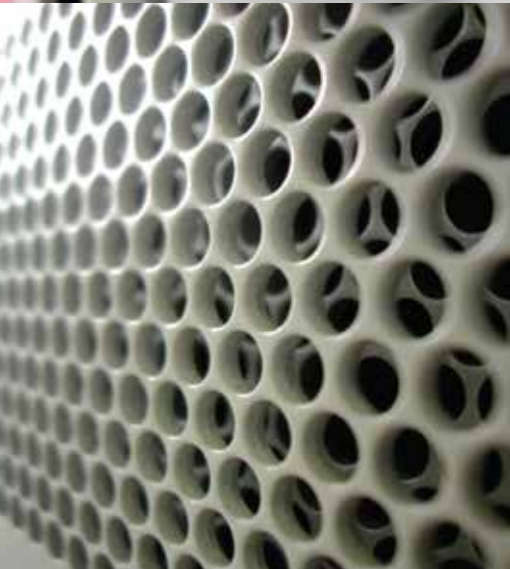

CONTENTS

High Resolution Optical Spectrum Analyzer	4
Optical Complex Spectrum Analyzer	6
OSA/OCSA Model Comparison Table	7
OSA/OCSA Specifications	8
Optical MultiTest Platform & Modules	
AP1000 series - Mainframe	10
AP3350 series - Tunable Laser Source module	11
AP3390 series - DFB Laser module	12
AP3314 series - Optical Power Meter module	13
AP3344 series - Optical Switches module	13
AP3364 series - Optical Variable Attenuator module	14
AP3370 series - Optical Amplifier (EDFA) module	15
AP3380 series - Optical Tunable Filter module	15

OPTICAL SPECTRUM ANALYZERS



Complex OSA

Combination of High Resolution OSA and Optical Modulation Analyzer

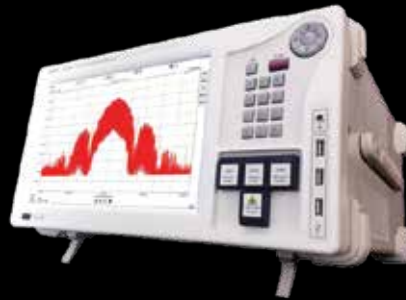

Top of the line OSA

The best specifications
Ultra High Resolution OSA



Fast sweep OSA

Combination of fast sweep and High Resolution OSA



Cost effective OSA

The best performance-price ratio High Resolution OSA



MULTI-TESTS PLATFORMS



Plug-in Modules

Tunable Laser Source, DFB Laser Source, Optical Amplifier (EDFA), Power Meter, Variable Optical Attenuator, Optical Tunable Filter, Optical Switch

THE WORLD HIGHEST RESOLUTION OPTICAL SPECTRUM ANALYZER

AP201X series
AP206X series
AP207X series
AP208X series

Features :

- From 5 MHz to 250 GHz resolution
- C, L & O Band
- +/- 2 pm wavelength accuracy
- High Dynamic range
- Rectangular-shape resolution filters
- High Close-in dynamic range
- Built-in tunable laser source

Applications :

- Advanced modulation formats analysis
- Comb generator measurement
- Laser characterization
- OSNR measurement
- Optical component characterization

Based on an interferometric principle, APEX Technologies ultra high resolution optical spectrum analyzer can achieve a 500 times better resolution than monochromator optical spectrum analyzer

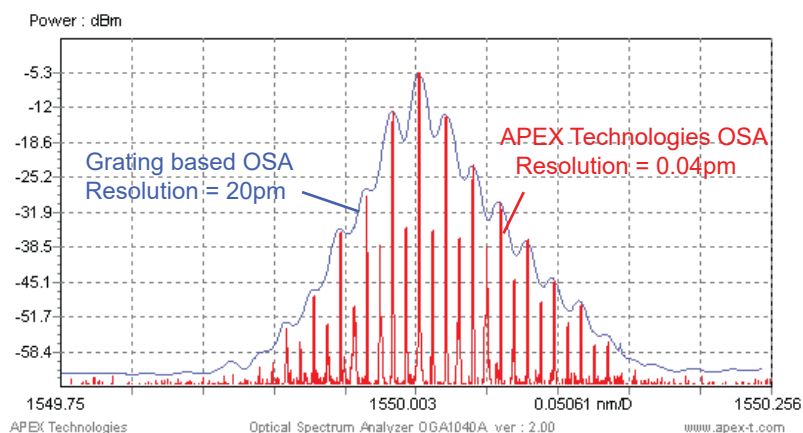

types measuring a 1.25 GHz modulated signal.

Direct comparison between the two different Optical Spectrum Analyzers

High Wavelength accuracy

The two different internal wavelength calibrators (absolute and relative) furnish to the equipment an accurate wavelength value of the TLS position. This technique provides a very high wavelength accuracy specification of +/- 2 pm.

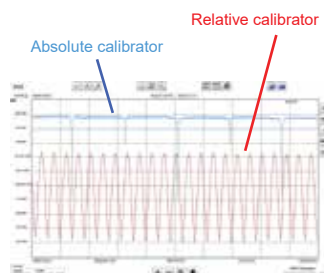

The absolute wavelength calibrator is a gas cell.

The relative one is a Fabry Perot with a fixed Free Spectral Range.

High Close-in dynamic range

The resolution of APEX Technologies OSA aren't related to optical filters but electrical ones. These electrical filters are close to rectangular shape. Thanks to these special electrical filter forms, the close-in dynamic range is very high :

- @ +/- 0.1 pm from the peak, dynamic > 40 dB
- @ +/- 0.4 pm from the peak, dynamic > 60 dB
- @ +/- 6 pm from the peak, dynamic > 80 dB

The high close-in dynamic range helps to well separate optical peaks which are extra-close to each other.

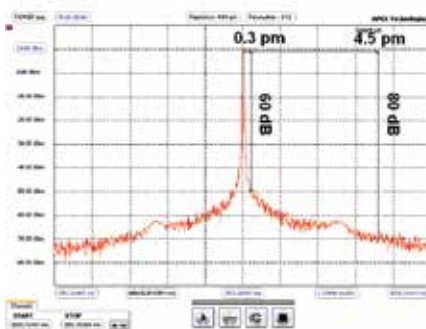

APEX Technologies OSA rectangular shape filters allow a nearly perfect integration of the signal over the selected resolution, while a grating based OSA filter integrates inside a wide base triangular shape. This sharp integration allows our OSA to perform a much more realistic level measurement.

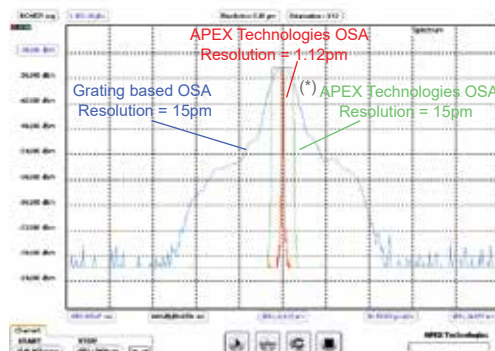

(*) APEX Technologies and grating based OSA wavelength resolution filters shapes comparison.

Two internal channels (one OSA per polarization axis)

Optionally two different additional PM inputs are available. The user can select between the input independent of polarization or the two PM inputs.

Input independent of polarization:

After splitting the input signal into two orthogonal polarization axis, analysed simultaneously by two internal independent channels. By using this method, APEX OSA can display the two polarization channels separately or recombine them and display a polarization independent measurement.

Two PM inputs:

The two input signals can be analysed simultaneously by two internal independent channels. By using this method, APEX OSA can display the two signals separately

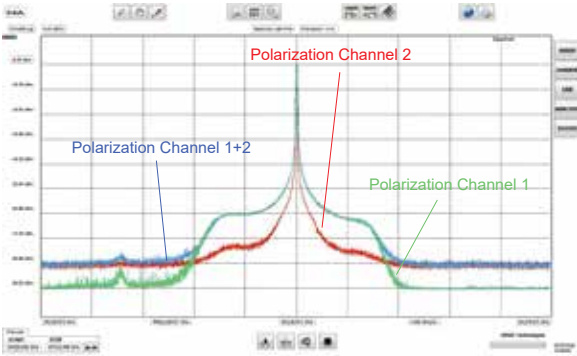

Polarization analysis

Optionally, the state of polarization can be measured. This measurement can be integrated over the full wavelength range of the polarimeter or as a function of wavelength. Three different displaying modes exist: Jones graph, Poincaré sphere.

Different detection modes are available: peak mode, area mode, point mode, threshold mode, markers mode.

The evolution of the state of polarization can be measured as a function of time, and as a function of wavelength.

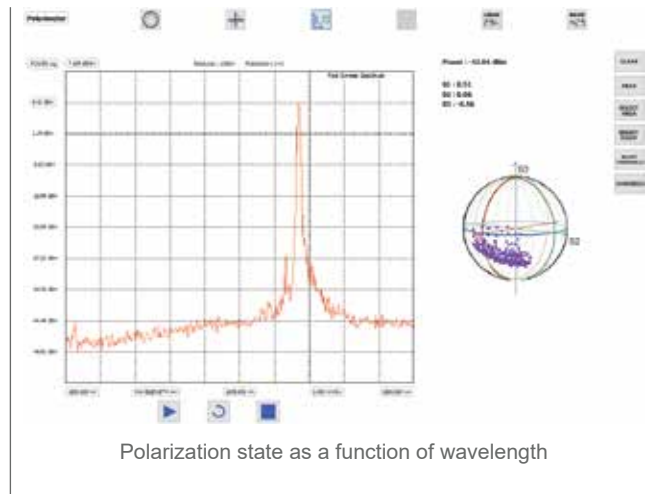
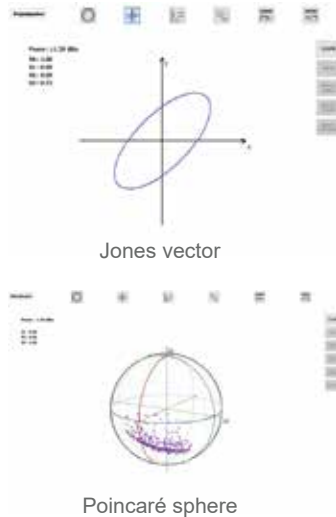

Polarization state as a function of wavelength

Combination of High resolution and High speed optical spectrum analysis

In order to meet the request of customers, for whom both high resolution and high speed are important, a new option is available for the OSA AP207x series. With this fast sweep option, a grating based OSA is integrated, and keeps scanning the full span with the speed of 70nm/s. By simply choosing an area in the grating OSA graph, the optical spectrum of the selected zone will be displayed with much more details by the High Resolution OSA.

Filter function

The equipment can be used as a 150 pm bandwidth tunable filter in the full C band. This functionality also gives the possibility to filter a chosen part of the input signal to monitor it through two different ways:

- with the internal power meters
- externally thanks to the filtered signal output

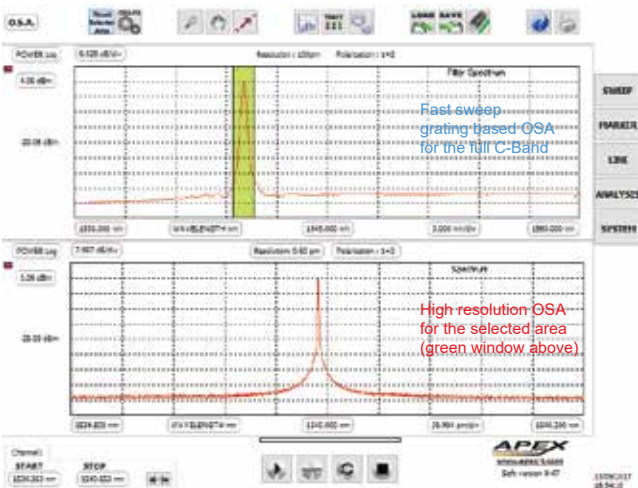

Tunable Laser Source & Tracking generator

- The built-in Tunable Laser Source local oscillator can also be used as an independent TLS. In option a TLS optical output and a control software can be integrated into the equipment.

- The tracking generator option allows the user to synchronise the wavelength TLS output with the OSA measurement. With this combination, active and passive components transmission measurements (insertion loss/gain) are possible with a dynamic range of 63 dB and a resolution of 1 MHz.

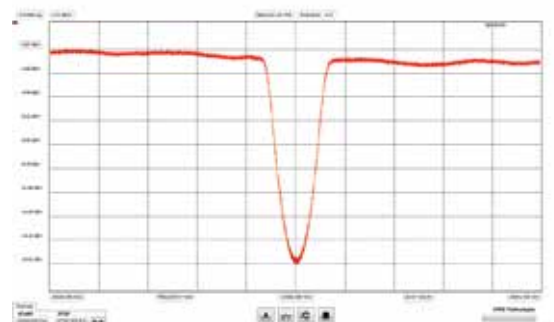

Bragg grating profile measurement using the tracking generator

OPTICAL COMPLEX SPECTRUM ANALYZER FOR ADVANCED MODULATION ANALYSIS

AP268X series

Features :

- From 5 MHz to 250 GHz resolution
- C, L & O Band
- +/- 2 pm wavelength accuracy
- High Dynamic range
- Rectangular-shape resolution filters
- High Close-in dynamic range
- Built-in tunable laser source
- No Baud rate limitation
- No modulation format limitation (BPSK, DPSK, 16QAM, 64QAM...)
- Phase, chirp, intensity vs time - Constellation - Eye diagram

Applications :

- Advanced modulation formats analysis
- Modulator characterization
- Comb generator temporal and spectral measurement
- Mode locked laser temporal and spectral measurement
- Chromatic dispersion analysis
- Complex transfer function of components

Use it as an high performances OSA and Optical Modulation Analyzer !

This equipment is based on interferometric method and is able to measure spectrums with the same specifications as the AP208x series instruments. It also has the added benefit of measuring phase as a function of frequency. The phase and intensity information can then be used to calculate chirp, phase, alpha parameter or pulse shape as a function of time, furthermore it can display constellation, phase and intensity eye diagrams.



Complex measurement setup

As mentioned, a complex measurement needs not only the intensity but also the phase as a function of frequency. To measure the phase, the signal under test must be a repetitive signal with a pattern frequency between 70 MHz to 900 MHz. Commercially available PPG and AWG are able to generate the right pattern length to match this pattern frequency range for any signal-rate.

A reference RF pattern clock repetition signal is also required. Manually, the user can plug an external clock to the equipment. To simplify the setup, a new optical clock recovery function is available, it allows to do complex measurement without reference clock signal.

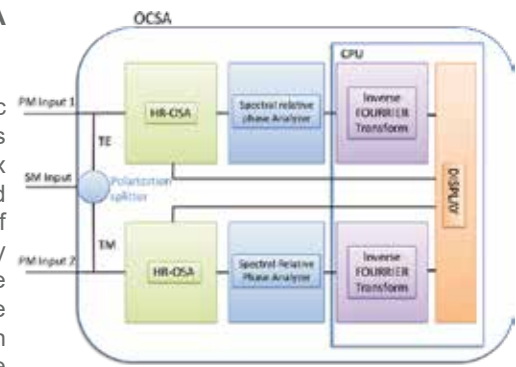

OCSA time-domain measurement advantages

Contrary to standard optical modulation analyzers and thanks to the fact that the measurement is made in the spectral domain, APEX Technologies OCSA haven't any real rate-limitation.

It means that you can see it as an utopist 3 THz bandwidth optical modulation analyzer without electronic limitation able to measure any modulated signal rates (from 70 Mbaud to ~ 1,5 Tbaud).

Furthermore, it doesn't need any special software adapted to each modulation format and can measure any of them even the very rare and the new ones.

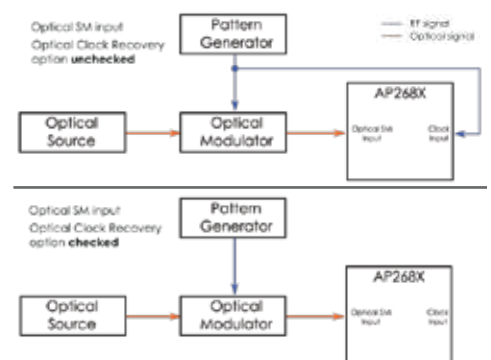

Measurement configuration with AP268x OCSA

User-friendly and powerful user interface

With only a few clicks, via the touch screen or USB mouse, you could have all types of results of your measurement displayed :

- High resolution spectrum
- Intensity and/or phase vs. frequency
- Intensity, phase, chirp, Alpha Parameter vs. time
- Eye diagram, constellation
- Group delay & chromatic dispersion
- Complex transfer function of components

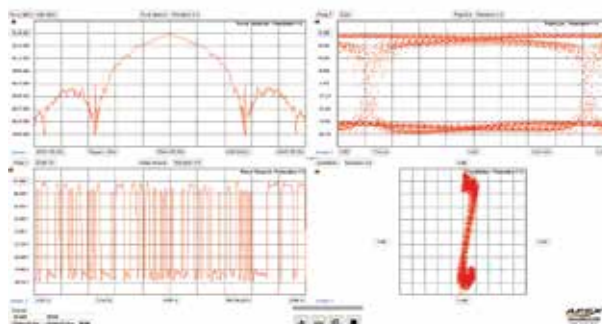

Optical complex analysis of a PRBS signal with the pattern length of 2^7-1

Wavelength range for different models:

	1260	1360	1460	1530	1565	1625
	O Band		E Band	S Band	C Band	L Band
AP2010, AP2060, AP2070				1526nm	41nm	1567nm
AP2011, AP2061, AP2071				1526nm	81nm	
AP2012, AP2062, AP2072					1567nm	40nm
AP2081, AP2681				1525nm	82nm	
AP2083, AP2683				1520nm	110nm	
AP2085, AP2685	1265nm	80nm	1345nm			1630nm
AP2086, AP2686	1265nm	80nm	1345nm	1525nm	82nm	1607nm
AP2087, AP2687	1265nm	80nm	1345nm	1520nm	110nm	1630nm

Comparison of OSA Series:



	AP201x Series	AP206x Series	AP207x Series	AP208x Series	AP268x Series
Wavelength Range					
O Band				✓	✓
C Band	✓	✓	✓		
L Band	✓	✓	✓		
C + L Band	✓	✓	✓	✓	✓
Extended C + L Band				✓	✓
O + C + L Band				✓	✓
Resolution Bandwidth					
Resolution Bandwidth			✓	✓	✓
5MHz			✓	✓	✓
20MHz	✓	✓	✓	✓	✓
100MHz			✓	✓	✓
140MHz		✓	✓	✓	✓
Virtual Resolution Bandwidth		✓	✓	✓	✓
Input Fibre Type for OSA					
SM Input		✓	✓	✓	✓
PM Input	✓		✓		
Built-in Tunable Laser Source					
DFB Laser	✓	✓	✓		
External Cavity Laser				✓	✓
Sweep Speed (Max.)					
1.2nm/s	✓	✓	✓		
35nm/s				✓	✓
Complex Measurement					
Complex analysis (Intensity, phase, chirp vs. Time); Constellation & Eye Diagram					✓
OPTION					
TLS output	✓	✓	✓	✓	✓
Tracking Generator	✓	✓	✓	✓	✓
Optical filtered output			✓	✓	✓
Polarimeter			✓	✓	✓
SM/PM input interface	✓				
5 MHz Resolution instead of 20 MHz		✓			
Fast sweep OSA (up to 70 nm/s)			✓		
2 additional PM input				✓	✓
Group delay and Chromatic dispersion analysis					✓

Technical specifications:

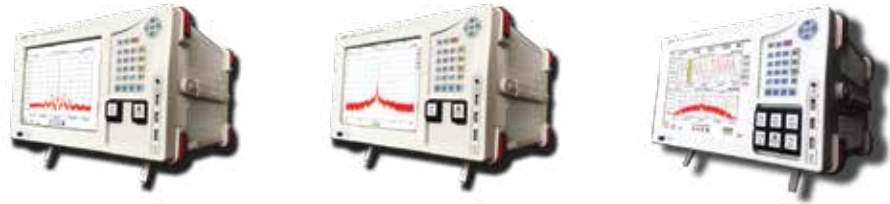

	AP201x Series	AP206x Series	AP207x Series
Wavelength measurement range	AP2010A : 1526 to 1567 nm AP2011A : 1526 to 1607 nm AP2012A : 1567 to 1607 nm	AP2060A : 1526 to 1567 nm AP2061A : 1526 to 1607 nm AP2062A : 1567 to 1607 nm	AP2070A : 1526 to 1567 nm AP2071A : 1526 to 1607 nm AP2072A : 1567 to 1607 nm
Wavelength span range	AP2010A : 170 pm to 41 nm AP2011A : 170 pm to 81 nm AP2012A : 170 pm to 40 nm	AP2060A : 170 pm to 41 nm AP2061A : 170 pm to 81 nm AP2062A : 170 pm to 40 nm	AP2070A : 170 pm to 41 nm AP2071A : 170 pm to 81 nm AP2072A : 170 pm to 40 nm
Wavelength resolution (@ 3 dB) ^d	20MHz/0.16pm	20MHz/0.16pm 140MHz/1.12pm Virtual Resolution Bandwidth	5MHz/0.04pm 140MHz/1.12pm 20MHz/0.16pm Virtual RBW 100MHz/0.16pm
Wavelength absolute accuracy ^{a,c}	+/- 2 pm Typ. (+/- 3 pm Max.)		
Dynamic range ^{a,f}	78 dB		
Close-in dynamic range ^{a,f}	>40 dB @ +/- 1.3 pm >60 dB @ +/- 8 pm >70 dB @ +/- 30 pm		
Spurious free dynamic ^{d,f}	50 dB ⁽¹⁾		
Sweep time ^d	Between 0.4 nm/s (min) & 1.2 nm/s (max)		
Measurement level range ^{a,f}	-68 dBm (monochromatic) to +10 dBm		
Absolute level accuracy ^{a,h}	+/- 0.3dB ⁽²⁾		
Level repeatability ^{a,b,d,h}	+/- 0.2dB		
Optical input	1x FC/APC for PM fibre input	1x FC/PC for SM fibre input	1x FC/PC for SM fibre input 2x FC/APC for PM fibre inputs
Internal WL calibrator	Yes		
Display capabilities			
X scale	Wavelength in nm or frequency in GHz		
Y scale	Optical power in mW or dBm		

Option specifications:

	Option 201x-01	Option 206x-01	Option 207x-01
Tunable Laser Source Specifications			
Wavelength range	Identical as the WL measurement range of the chosen model		
Spectrum line width (@ 3 dB)	3 MHz Typical		
Output power	-3 dBm Typical		
SMSR	> 50 dBc		
ASE	< - 50 dBc over 0.1 nm		
RIN	-135 dB/Hz		
Wavelength stability	1 pm @ 15 min, 2 pm @ 1 h		
Power stability	0.07 dB @ 15 min, 0.09 dB @ 1 h		
Fiber/connector type	PM fibre FC/APC connector	SM fibre FC/APC connector	
Optical tracking generator specifications			
Dynamic ^h	55 dB		
Resolution	1 MHz		

Option 201x-02
Input interface from PM to SM fibre

Option 206x-02
5 MHz wavelength resolution filter instead of 20 MHz

Option 207x-02	
Fast Sweep OSA + Optical filtered output (C Band only)	
Wavelength measurement range	1529 nm to 1564 nm
Wavelength resolution (@3dB) ^d	12.5 GHz/100 pm
Sweep time ^d	70 nm/s (2 Hz for C Band)
Optical filter insertion loss ^{a,d}	3 dB
Optical filter RBW (@ 3 dB)	50 GHz
Option 207x-03	
Fast Sweep OSA + Optical filtered output + Polarimeter (C Band only)	

a) At 1550 nm
b) At 0 dBm
c) After Wavelength calibration
d) Typical
e) Resolution 5 MHz
f) Resolution 20 MHz

g) Resolution 100 MHz
h) Resolution 140 MHz
1) Inside spurious free dynamic
2) Relative to total signal power
Otherwise: possible power offset (mW)
< 10⁻⁶ x total signal power (mW)

Optical spectrum analyzer specifications:

	AP2081A/AP2681A	AP2083A/AP2683A	AP2085A/AP2685A	AP2086A/AP2686A	AP2087A/AP2687A
Wavelength measurement range	1525 nm to 1607 nm	1520 nm to 1630 nm	1265 nm to 1345 nm	1525 nm to 1607 nm 1265 nm to 1345 nm	1520 nm to 1630 nm 1265 nm to 1345 nm
Wavelength span range ^h	80 pm to 82 nm	80 pm to 110 nm	80 pm to 80 nm	80 pm to 82 nm	80 pm to 110 nm
Wavelength resolution (@ 3 dB) ^d	5MHz/0.04pm 10GHz/80pm	20MHz/0.16pm 50GHz/0.4nm	100MHz/0.8pm 100GHz/0.8nm	140MHz/1.12pm 200GHz/1.6nm	2GHz/16pm 400GHz/3.2nm
Dynamic range ^{a e}	83 dB		79 dB	83 dB ⁱ 79 dB ^k	83 dB ^j 79 dB ^k
Close-in dynamic range ^{a e}		>40 dB @ +/- 0.1 pm	>60 dB @ +/- 0.4 pm	>80 dB @ +/- 6 pm	
Spurious free dynamic ^d	55 dB Typical (50 dB min)				
Sweep time ^{d g}	35 nm/s (preliminary)				
Wavelength absolute accuracy ^{a c}	+/- 2 pm typical (+/- 3 pm Max.)				
Measurement level range ^{a e}	-73 dBm (monochromatic) to +10dBm		-69 dBm to +10dBm	-73 dBm to +10dBm ⁱ -69 dBm to +10dBm ^k	-73 dBm to +10dBm ^j -69 dBm to +10dBm ^k
Absolute level accuracy ^{a b h}	+/- 0.3 dB (monochromatic)				
Level repeatability ^{a b d h}	+/- 0.2 dB				
Optical input	FC/PC for SM fibre				
Internal absolute WL calibrator	Yes				
Display capabilities					
X scale	Wavelength in nm or frequency in GHz				
Y scale	Optical power in mW or dBm				
Option 208x-01/Option 268x-01					
Optical tunable laser source specifications					
Wavelength range	Identical as the wavelength measurement range of the chosen model				
Spectrum line width (@ 3 dB)	500 kHz typical				
Output power	-5 dBm typical		-12 dBm typical	-5 dBm typical ⁱ -12 dBm typical ^k	-5 dBm typical ^j -12 dBm typical ^k
SMSR	>45 dBc				
ASE	< -40 dBc over 0.1 nm				
RIN	< -135 dB/Hz				
Wavelength stability	+/- 10 pm over 1 hour				
Power stability	+/- 0.09 dB over 1 hour				
Fibre/connector type	SM fibre FC/APC connector				
Option 208x-02/Option 268x-02					
Optical tracking generator specifications					
Dynamic ^e	63 dB		59 dB	63 dB ⁱ 59 dB ^k	63 dB ^j 59 dB ^k
Resolution	1 MHz				
Option 208x-03/Option 268x-03					
Optical inputs	1x FC/PC for SM fibre input + 2x FC/APC for PM fibre inputs				
Option 208x-04/Option 268x-04					
Optical filtered output + Polarimeter (C Band only)					
Optical filter insertion loss ^{a d}	6 dB				
Optical filter RBW (@ 3 dB)	50 GHz				
Option 268x-05					
Group delay and chromatic dispersion analysis					

Optical modulation analyzer specifications:

	AP268x Series OCSA
Spectrum domain measurement	Intensity, Phase
Time domain measurement	Intensity, Phase, Chirp, Constellation, Eye Diagram (Intensity/Phase)
Clock input frequency	Clock frequency = pattern frequency ^f
Optical Bandwidth	3 THz
Polarization	2 Modulation Analyzers, 1 for each polarization channel
Clock power	> -17 dBm at pattern frequency ^f
Pattern frequency	From 70 MHz to 900 MHz
Optical spectral components measurement sensibility	-70 dBm
Maximum temporal resolution	325 fs
Measurement time	6 nm (750 GHz) /s
The pattern frequency^f must be included in the pattern frequency range	
For example at 10 GBaud : you can use any pattern length between 10 and 142 (PRBS 2 ⁷ -1 included) For example at 28 GBaud : you can use any pattern length between 28 and 400 (PRBS 2 ⁷ -1, 2 ⁸ -1 included) For example at 40 GBaud : you can use any pattern length between 40 and 571 (PRBS 2 ⁷ -1, 2 ⁸ -1, 2 ⁹ -1 included) For example at 100 GBaud : you can use any pattern length between 100 and 1428 (PRBS 2 ⁷ -1, 2 ⁸ -1, 2 ⁹ -1, 2 ¹⁰ -1 included) For example at 400 GBaud : you can use any pattern length between 400 and 5714 (PRBS 2 ⁹ -1, 2 ¹⁰ -1, 2 ¹¹ -1, 2 ¹² -1 included) For example at 1000 GBaud : you can use any pattern length between 1000 and 14285 (PRBS 2 ¹⁰ -1, 2 ¹¹ -1, 2 ¹² -1, 2 ¹³ -1 included)	
The equipment has no Baud rate upper limitation and it can measure any modulation format	



- a) At 1550 nm
- b) At 0 dBm
- c) After Wavelength calibration
- d) Typical
- e) Resolution 5 MHz
- f) Resolution 20 MHz
- g) Resolution 140 MHz
- h) Resolution 140 MHz
- i) 1525 nm to 1607 nm
- j) 1520 nm to 1630 nm
- k) 1265 nm to 1345 nm
- l) Pattern frequency = Baud Rate / Pattern Length

HIGH PERFORMANCE & COST EFFECTIVE OPTICAL MULTITEST PLATFORM

BUILD YOUR OWN FLEXIBLE MULTI-TEST SYSTEM

AP1000-2
AP1000-5
AP1000-8
AP1000-12

Features :

- A variety of measurement modules
- Three USB connectors on the front panel
- Internal memory
- GPIB and Ethernet remote control

- .txt file format

- 5.7 inch touchscreen

Modules :

- Tunable Laser Source
- DFB Laser
- Optical Power Meter
- Optical Amplifier (EDFA)
- Optical Variable Attenuator
- Optical Tunable Filter
- Optical Switch
- Others



AP1000-2 mainframe controller:
- Accepts up to 2 modules



AP1000-5 mainframe controller:
- Accepts up to 5 modules



AP1000-8 mainframe controller:
- Accepts up to 8 modules
- Can control up to 7 AP1000-12 (92 modules in total)



AP1000-12 mainframe expansion:
- Accepts up to 12 modules
- Can be controlled by AP1000-8 or work independently
- Allows the system to integrate up to 92 test modules using a single AP1000-8

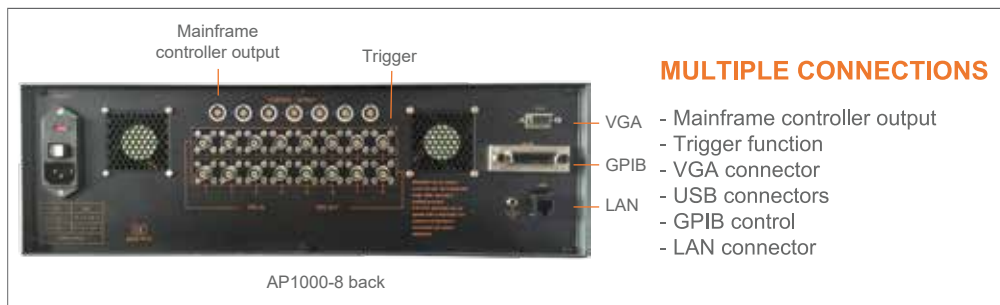

SPECIFICATIONS

	AP1000-2	AP1000-5	AP1000-8	AP1000-12
Modules room	2	5	8	12
USB connectors	3	3	3	2
Internal memory	Yes	Yes	Yes	Yes
File format	.txt format			
GPIB connector	Yes	Yes	Yes	Yes
Ethernet connector	Yes	Yes	Yes	Yes
Mainframe controller outputs	No	No	7	No
Screen	Yes	Yes	Yes	No
Operating temperature	15°C to 35°C			
Power requirement	AC 100 to 120 V/200 to 250 V, 50/60 Hz			

STORAGE

- 64 Gb hard drive
- 3 ports USB
- bmp, txt and setup file formats

EQUIPMENT CONTROL

- The touch screen
- Mouse and keyboard

REMOTE CONTROL

- Control and perform data transfer with a computer through GPIB or ethernet.
- Remote control of the equipment through Internet

Tunable Laser Source modules

VERY GOOD PERFORMANCE TO PRICE RATIO SOLUTIONS



Features:

- Continuous sweeping
- ITU channels selection
- Narrow linewidth: ~ 300 kHz
- High output Power: maximum +13 dBm
- Ultra High wavelength accuracy: +/- 6 pm
- High SMSR: > 47 dB
- Narrow wavelength setting resolution : < 1pm
- Wavelength Etalon Access option

Software features:

- Output modes
 - Static
 - Continuous sweep
 - Step by step sweep
 - Grid
- Scale modes
 - Wavelength or frequency
 - mW or dBm
- Calibration offset access
- Other modules measurement display

New

Low SSE, high dynamic range tunable laser source

This new laser synchronizes the sweeps of our tunable laser source with an internal grating tunable filter. This combination gives the possibility to measure the transfer function of components with an extra high dynamic.

Low SSE, > 85 dB, measured by OSA with a resolution of 0.1 nm

Specifications:

	AP3350A	AP3352A
Wavelength range	1526 nm to 1567 nm	1567 nm to 1608 nm
Wavelength setting resolution	1 pm	
Spectrum line width @ 3 dB	300 kHz typical	500 kHz typical
Wavelength accuracy	+/- 6 pm	
Output power	10 dBm typical	
Output power adjustment	> 20 dB	
SMSR	47 dB (within a 0.1 nm resolution)	
Signal to source spontaneous-emission ratio	67 dB (within a 140 MHz resolution filter at +/- 0.2 nm from the signal)	
Optical isolation	25 dB	
RIN	-135 dB/Hz	
Wavelength stability @ +9 dBm	1 pm @ 15 min, 2 pm @ 1 h	
Power stability @ +9 dBm	0.03 dB @ 15min, 0.05 dB @ 1h	
Static Wavelength tuning speed	Max. 3 s between any two static wavelength positions	
Continuous Sweeping Speed	Adjustable from 0.11 to 1.5 nm/s	
Fiber/connector type	Polarization maintaining fiber FC/APC connector	
Operating temperature	From 15°C to 35°C	
Option TLS01	+13 dBm maximum output power	
Option TLS02	External sine modulation (from 10 kHz to 20 MHz)	
Option TLS03	Wavelength etalon access (extracting the laser wavelength position during a continuous sweep)	

DFB Laser modules

ITU GRID COVERING C-BAND, L-BAND AND O-BAND



Features:

- Selected wavelength according to ITU-T Grid, C-band, L-band and O-band available
- High optical output power up to 20 mW for C-band & L-band, up to 16 mW for O-band
- High side mode suppression ratio (SMSR)
- 50GHz spacing available
- Narrow linewidth (down to 1 MHz) available

Specifications:

	AP3390A	AP3392A	AP3395A
Peak Emission Wavelength	ITU-Grid for C-band	ITU-Grid for L-band	Min. 1290 nm; Max. 1330 nm
Spectrum line width @ 3 dB	1 MHz		5MHz
Output power	20 mW Typ.		16 mW Typ.
Wavelength accuracy	+/- 6 pm		
Wavelength tunability	3 nm (without mode hopping)		
Side Mode Suppression Ratio	45 dB Typ.		
Min. optical isolation	30 dB		
RIN	-138 dB/Hz		-155 dB/Hz
Polarization Extinction Ratio	20 dB		
Fiber/connector type	Polarization maintaining fiber Standard FC/PC connector (FC/APC under request)		Corning SMF-28 FC/PC connector
Operating temperature	From 20°C to 35°C		

ITU Frequency table:

AP3390A (C-band):

Wavelength (nm)	ITU Freq. (THz)	Wavelength (nm)	ITU Freq. (THz)	Wavelength (nm)	ITU Freq. (THz)	Wavelength (nm)	ITU Freq. (THz)
1529.55	196.00	1538.98	194.80	1548.51	193.60	1558.17	192.40
1530.33	195.90	1539.77	194.70	1549.32	193.50	1558.98	192.30
1531.12	195.80	1540.56	194.60	1550.12	193.40	1559.79	192.20
1531.90	195.70	1541.35	194.50	1550.92	193.30	1560.61	192.10
1532.68	195.60	1542.14	194.40	1551.72	193.20	1561.42	192.00
1533.47	195.50	1542.94	194.30	1552.52	193.10	1562.23	191.90
1534.25	195.40	1543.73	194.20	1553.33	193.00	1563.05	191.80
1535.04	195.30	1544.53	194.10	1554.13	192.90	1563.86	191.70
1535.82	195.20	1545.32	194.00	1554.94	192.80	1564.68	191.60
1536.61	195.10	1546.12	193.90	1555.75	192.70		
1537.40	195.00	1546.92	193.80	1556.55	192.60		
1538.19	194.90	1547.72	193.70	1557.36	192.50		

AP3392A (L-band):

Wavelength (nm)	ITU Freq. (THz)	Wavelength (nm)	ITU Freq. (THz)	Wavelength (nm)	ITU Freq. (THz)	Wavelength (nm)	ITU Freq. (THz)
1565.50	191.50	1577.03	190.10	1588.73	188.70	1600.60	187.30
1566.31	191.40	1577.86	190.00	1589.57	188.60	1601.46	187.20
1567.13	191.30	1578.69	189.90	1590.41	188.50	1602.31	187.10
1567.95	191.20	1579.52	189.80	1591.26	188.40	1603.17	187.00
1568.77	191.10	1580.35	189.70	1592.10	188.30	1604.03	186.90
1569.59	191.00	1581.18	189.60	1592.95	188.20	1604.88	186.80
1570.42	190.90	1582.02	189.50	1593.79	188.10	1605.74	186.70
1571.24	190.80	1582.85	189.40	1594.64	188.00	1606.60	186.60
1572.06	190.70	1583.69	189.30	1595.49	187.90	1607.47	186.50
1572.89	190.60	1584.53	189.20	1596.34	187.80	1608.33	186.40
1573.71	190.50	1585.36	189.10	1597.19	187.70	1609.19	186.30
1574.54	190.40	1586.20	189.00	1598.04	187.60	1610.06	186.20
1575.37	190.30	1587.04	188.90	1598.89	187.50	1610.92	186.10
1576.20	190.20	1587.88	188.80	1599.75	187.40	1611.79	186.00

Optical Power Meter modules

STANDARD DISPLAY RANGE FROM -80 dBm TO + 10 dBm
HIGH POWER DISPLAY RANGE FROM -60 dBm TO + 33 dBm



Features:

- 1 or 2 inputs
- Wavelength range : 800 to 1 700 nm
- Display range : -80 to +10 dBm & -60 to +30dBm
- Different style of interchangeable connectors
- InGaAs Photo diode

Software features:

- 2 inputs immediate display
- Scale modes : mW or dBm
- Min/Max percentage function
- Other modules measurement display
- Active Power Control function :
Maintains a constant optical output power
(Available with EDFA module and/or
Variable Optical Attenuator module)

Specifications:

	AP3314A-1 (one input +10dBm max) AP3314A-11 (Two inputs +10dBm max)	AP3314A-3 (one input +33dBm max) AP3314A-33 (Two inputs +33dBm max)
	AP3314A-13 (Two inputs; one +10dBm max plus one +33dBm max)	
Wavelength range	800 to 1700 nm	
Calibrated wavelengths	980,1310, 1480,1550,1610 nm	
Photo diode	InGaAs	
Fiber type	9/125 to 50/125 μm	
Display range ⁽²⁾	-70 to +10dBm	-50 to +30dBm
Display range after zeroing ⁽²⁾	-80 to +10dBm	-60 to +30dBm
Max. permitted level	+10dBm	+30dBm (+33dBm few min)
Intrinsic uncertainty ⁽¹⁾	± 0.21 dB (±5%)	
Overall measurement uncertainty	-80 to +10dBm 980nm ±0.5dB ±0.2nW 1310~1610nm ±0.2dB ±0.1nW	-60 to +30dBm (+33dBm few mn) 980nm ±0.5dB ±20nW 1310~1610nm ±0.2dB ±10nW
Optional optical connectors	FC (female): Different styles of optical connector interchangeable adapter (ST/SC/...) and bare optical fiber adapter can be defined by customer.	
Fiber type	Single-mode or Multimode 9/125 or 50/125 μm	
Ambient temperature	Nominal range of use -10°C to +40°C ; Storage and transport -40°C to +70°C	

Optical Switch modules

1x2, 2x2, 1x4, 1x8 SWITCHES



Features:

- Wide Operating wavelength range
- Low Insertion loss
- Low Polarization dependence loss
- Fast Switch speed

Software features:

- Easy control
- Other modules measurement display

Specifications:

	AP3344A Switches			
	1x2	2x2	1x4	1x8
Wavelength	1290~1330 nm and 1525~1610 nm			
Insertion loss (max)	0.8 dB	0.9 dB	1.0 dB	1.5 dB
Return loss (min)	45 dB			
Polarization Dependent loss (max)	0.07 dB		0.1 dB	
Crosstalk (min)	60 dB			
Repeatability (max)	+/- 0.02 dB		+/- 0.05 dB	
WDL (max)	0.2 dB			
Switch time (max)	4 ms		10 ms	
Durability (min)	10 ⁷ times			
Operating temperature	-10 to +40°C			

Variable Optical Attenuator modules

ATTENUATION RANGE OF 30 dB, ATTENUATION STEP OF 0.01 dB



Features:

- Simple or Double module
- Attenuation range: 30dB
- Minimum insertion loss: < 1dB
- Attenuation step: 0.01 dB

Software features:

- 2 channels immediate display
- Attenuation controlled by powermeter
- Other modules measurement display

AP3364-B-2 Wide attenuation range and multifunctional Optical Attenuator

New

This new Optical Attenuator Module is based on a highly integrated combination of dual variable attenuators and optical switch in a one slot module. This multifunctional attenuator works in 3 modes: Dual Attenuator Mode, Single Attenuator Mode and Switch Mode. In Dual Attenuator mode, the module can work as 2 independent attenuators. In Single Mode, the module provides a wider attenuation range, including a shutter function. In Switch Mode, this module can work as a 2x2 Optical Switch.



- Dual attenuator mode:**
- 2 channels simultaneous display
 - 30 dB attenuation for each channel



- Single attenuator mode:**
- 60 dB total attenuation
 - Shutter function

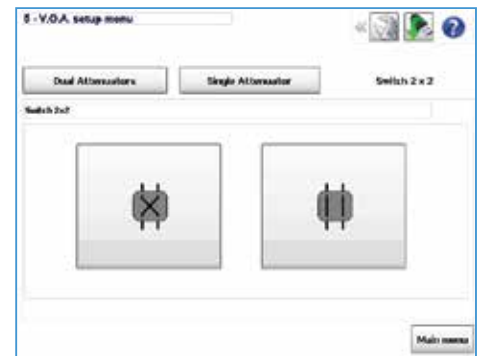

- Switch mode:**
- Switch 2 x 2

Specifications:

	AP3364A (simple VOA) & AP3364A-2 (double VOA)		AP3364B-2	
	Dual VOA mode	Single VOA mode	Switch mode	
Wavelength range	1310 nm & 1550 nm			
Attenuation range	30 dB	60dB		
Attenuation step size	0.01 dB			
Insertion loss	< 1 dB	< 2 dB	< 2.5 dB	
Temperature dependence loss	< 0.2 dB		≤ 0.25 dB	
Wavelength dependence loss	< 0.3 dB			
Polarization dependence loss	< 0.2 dB			
Polarization mode dispersion	< 0.1 ps			
Return loss	>45 dB			
Response speed	< 100 ms / 3 dB			
Attenuation setting repeatability	< +/- 0.05 dB			
Attenuation setting backlash	< 0.2 dB			
Maximum optical power	300 mW			
Operating temperature	-15°C to 35°C			

EDFA modules

HIGH GAIN, LOW NOISE FIGURE, SATURATED OUTPUT POWER ACHIEVES UP TO +22 dBm.



Features:

- 3 series of EDFA module in standard version
 - Booster / Line / Pre-amplifier
- Gain flattened version available
- Input power down to -30 dBm
- Saturated output power up to 22 dBm
- Wavelength range 1528 to 1563 nm
- Large input power range
- Low noise figure
- Easy control

Software features:

- Manual or Automatic control
- Output and Gain control
- Scale modes: mW or dBm
- Easy parameter access
- Other modules measurement display

Specifications:

	AP3370A Booster Amplificateur			AP3370B Line Amplificateur			AP3370C Pre-Amplificateur		
	Min.	Typ.	Max.	Min.	Typ.	Max.	Min.	Typ.	Max.
Output Power (dBm)	From +13 dBm to +22 dBm according to the model ^a						From -10 dBm to +10 dBm according to the model ^a		
Input Power range ^b (dBm)	-10	0	+4	-20	-10	0		-30	
Operating Wavelength range (nm)	1528 to 1563 nm								
Noise Figure ^c (dB)		4.5	5		5.0	6.0		5.0	5.5
Polarization Dependent Loss (dB)	≤ 0.3								
Polarization Dependent Gain (dB)	≤ 0.3			≤ 0.5					
Polarization Mode Dispersion (ps)	≤ 0.3			≤ 0.5					
Pump Power Leakage (dB)	-30 Max.								
Output & Input Isolation (dB)	≥ 30								
Return Loss (dB)	≥ 40								
Fiber Type	SMF-28, 900 μm loose tube								
Operating Temperature (°C)	0 to 65 °C								

- a) Pin = 0 dBm
- b) The range of optical input power can be specified.
- c) Pin = -6 dBm
- d) Pin = -30 dBm

Optical Tunable Filter modules

C-BAND AND L-BAND TUNABILITY AND ATTRACTIVE FEATURES



Features:

- Excellent MEMS durability, thermal stability, and repeatability
- Superior optical performance
- Gaussian-shaped pass band
- Pass band optimized for 50 GHz channel spacing
- Customized pass bands and tuning ranges available

Specifications:

	AP3380A	AP3382A
Tuning Range	1529 to 1564 nm	1575 to 1610 nm
Min IL @ Peak ¹	< 4.0 dB	
Bandwidth @ 3 dB	> 0.15 nm	
Bandwidth @ 20 dB	< 0.68 nm	
Back Reflection	> 40dB	
PDL	< 0.3 dB	
Setting Error	< +/- 50 pm	
Tuning Resolution	10 pm	
Tuning Speed	< 30 ms	
Optical Power	< 500 mW	
Durability	> 1 billion cycles	
Operating Temperature	-5 to 70 °C	
Storage Temperature	-40 to 85 °C	
Fiber Type	9/125 μm single mode	

1. IL measured at 25 °C. IL < 5.0dB over entire operating temperature range.

Optical Transmission Spectrum*:

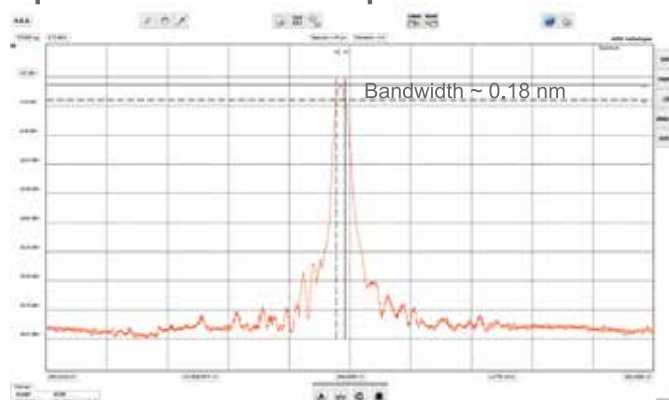

Optical transmission spectrum of AP3380A C-band Tunable filter

* The spectrum is obtained by the AP208x series Optical Spectrum Analyzer using the tracking generator feature with 1 MHz resolution.

International distributors

AMERICA

USA

Photonix Edge, LLC
1710 Mac Arthur Road
Suite 222
Whitehall, PA 18052

E-mail: yves@photonixedge.com
Phone: 610-462-7499
www.photonixedge.com

USA

New Jersey & Delaware

Advanced Technical Marketing
1719 Route 10, Suite 113
Parsippany, NJ 07054

E-mail: sales@atm1.com
Phone: 973-683-1411
www.atm1.com

ASIA

China

LUSTER LightTech Co., Ltd.
Building No.7, Yard No.13,
Cuihu Nanhuan Road,
Haidian District, Beijing 100094

Phone: +86-10-52348661
E-mail: ledu@lusterinc.com
www.lusterinc.com

Japan

HIKARI, INC
Yushima Fuji bldg. 301,
3-13-8 Yushima Bunkyo-ku
Tokyo 113-0034

Phone: (03) 3832 3117
E-mail: contact@hikari-trading.com
www.hikari-trading.com

South Korea

Panoptics Corp.
D-908 Bundang Technopark,
700 Pangyoro, Bundang,
Seongnam, Gyeonggi, 13516

Phone: +82-502-702-9999
E-mail: panoptics@panoptics.net
www.panoptics.net

Taiwan

Optical Scientific Corp.

7F-2, No. 421, Sung Shan Rd.
Taipei 11083

Phone: 886-2-2346-1510
E-mail: sales@toptical.com.tw
www.toptical.com.tw

EUROPE

France

ABSYS s.a.
19 Rue Levacher Cintrat
91460 Marcoussis

E-mail: ventes@absysfrance.com
Phone: 01 69 63 26 36
www.absysfrance.com

Israel

FAST Laser GROUP Ltd.
Shalom Aleichem 1 st,
Hod-Hasharon 4521456

E-mail: nachum@fastlaser.co.il
Phone: 972-(0)9-7444-112
www.fastlaser.co.il

Russia

OES Specpostavka
52/liter D, Fontanka river
embankment
191002 Saint-Petersburg

E-mail: contact@oessp.ru
Phone: +7812777080 ext.316
www.oessp.ru

Russia

Scientific equipment
Inzhenernaya street,
4a - 212
630128 Novosibirsk

E-mail: sales@spegroup.ru
Phone: +7(383) 383 24 06
www.spegroup.ru

Russia

Versia
Yablochkova street, 21,
Building 3, 3th floor
191002 Moscow

E-mail: info@versia-it.ru
Phone: +7(495) 616 10 00
www.versia-it.ru

UK

Lambda Photometrics Ltd.
Lambda House, Batford Mill
Harpenden,
Hertfordshire, AL5 5BZ

E-mail: contact@lambdaphoto.co.uk
Phone: +44(0)1582 764334
www.lambdaphoto.co.uk

After-sales service

North America

Photonix Edge, LLC
1710 Mac Arthur Road
Suite 222
Whitehall, PA 18052
USA

E-mail: yves@photonixedge.com
Phone: 610-462-7499
www.photonixedge.com

China

LUSTER LightTech Co., Ltd.
Building No.7, Yard No.13,
Cuihu Nanhuan Road,
Haidian District, Beijing 100094
China

Phone: +86-10-52348673
E-mail: zhijunzhang@lusterinc.com
www.lusterinc.com

Other Areas

APEX Technologies
9bis, Rue Angiboust
P.A. de la Fontaine de Jouvence
91460 Marcoussis
France

E-mail: sales@apex-t.com
Phone: +33 (0)1 69 63 26 30
www.apex-t.com

APEX

TECHNOLOGIES

Your local contact

Headquarters

APEX Technologies
9bis, rue ANGIBOUST
91460 MARCOUSSIS
FRANCE
Tel: +33 (0)169632630
Fax: +33 (0)169632637
E-mail: sales@apex-t.com